

# MADELEC AERO

FSCM : F9503

## ABBREVIATED COMPONENT MAINTENANCE MANUAL

### PHOTOLUMINESCENT FLOOR PROXIMITY EMERGENCY ESCAPE PATH MARKING SYSTEM TYPE 566 FOR CANADAIR CRJ-700

#### LIST OF REVISIONS

Rev. No.	1	2	3	4	5	6	7
Rev. Date	Oct 19/99						

#### LIST OF EFFECTIVE PAGES

Page 1 of 4    Oct 19/99                      Page 2 of 4    Oct 19/99  
Page 3 of 4    Oct 19/99                      Page 4 of 4    Oct 19/99

TASK 33-52-13-870-801

1. Description and operation

The system consists of photoluminescent strips installed along each side of cabin passengers aisle. At the wing emergency exit level two strip are positioned perpendicularly to each aisle strip. Each strip consists of a photoluminescent tape installed inside a polycarbonate profile consisted of a translucent cover and a base fitted together. End-caps are installed to every strip end. As there is no emergency exit door at the aft cabin, red arrows are printed on the photoluminescent tape pointed to the nearest emergency exit door. The system is installed on the floor with double side adhesive.

Approximate Dimensions :

- thickness = 0.2 inch; width = 1.38 inch

2. Testing and Fault Isolation

Not Applicable

3. Schematics and Wiring Diagrams

Not Applicable

# MADELEC AERO

FSCM : F9503

## ILLUSTRATED PARTS CATALOG

### PHOTOLUMINESCENT FLOOR PROXIMITY EMERGENCY ESCAPE PATH MARKING SYSTEM TYPE 566 FOR CANADAIR CRJ-700

#### LIST OF REVISIONS

Rev. No.	1	2	3	4	5	6	7
Rev. Date	19/10/99	15/12/99	01/02/00	04/07/00	03/07/01		

#### LIST OF EFFECTIVE PAGES

Page 1 of 3    July 03/01                      Page 2 of 3    July 03/01  
Page 3 of 3    July 03/01                      Page 4 of 4    July 03/01

P/N : 111-RJ7-001	211-RJ7-SA001	211-RJ7-SA002
505-802	505-8031	
801-RJ7-0112	801-RJ7-0157	801-RJ7-0162
801-RJ7-0196	801-RJ7-0205	801-RJ7-0232
801-RJ7-0322	801-RJ7-0482	801-RJ7-0499
801-RJ7-0570	801-RJ7-0578	801-RJ7-0649
801-RJ7-0657	801-RJ7-0676	801-RJ7-0684
801-RJ7-0909	801-RJ7-0917	801-RJ7-0957
801-RJ7-1050	801-RJ7-1399	801-RJ7-1431
801-RJ7-1439		

# MADELEC AERO

FSCM : F9503

## ILLUSTRATED PARTS CATALOG

Figure 1

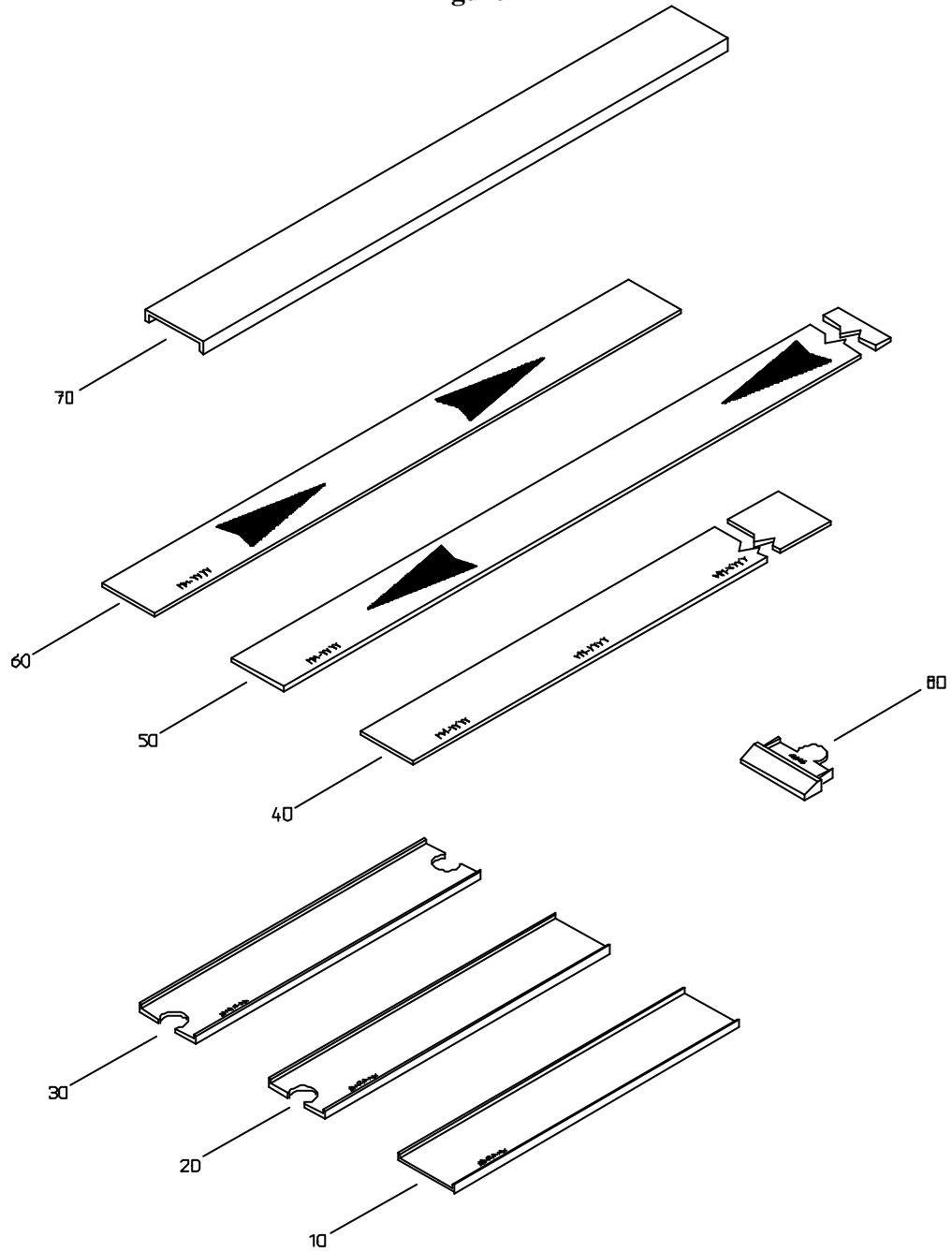

# 33-52-13

Page 2 of 4  
July 03/01

# MADELEC AERO

FSCM : F9503

## ILLUSTRATED PARTS CATALOG

Fig. Item	Part Number	Airline Stock N°	Nomenclature	Usage Code	Units /Assy
			1234567		
01 -001A	566-RJ7-01		PL-FPEEPM system No. BA670-40601		REF
-001B	566-RJ7-02		PL-FPEEPM system No. BA670-40602		REF
-001C	566-RJ7-03		PL-FPEEPM system No. BA670-40607		REF
-001D	566-RJ7-04		PL-FPEEPM system No. BA670-40606		REF
-001E	566-RJ7-05		PL-FPEEPM system No. BA670-40614		REF
-001F	566-RJ7-06		PL-FPEEPM system No. BA670-40619		REF
010A	801-RJ7-0482		.Base	A, B	2
010C	801-RJ7-0499		.Base	C, D, E, F	2
010A	801-RJ7-0570		.Base	A, B	2
010B	801-RJ7-1050		.Base	B	1
010A	801-RJ7-1399		.Base		2
010A	801-RJ7-1431		.Base	A, B	2
010C	801-RJ7-1439		.Base	C, D, E, F	2
020B	801-RJ7-0157		.Base	B	1
020A	801-RJ7-0196		.Base	A, B	2
020C	801-RJ7-0205		.Base	C, D, E, F	2
020C	801-RJ7-0322		.Base	C, F	2
020D	801-RJ7-0578		.Base	D, E	2
020A	801-RJ7-0649		.Base	A	2
020D	801-RJ7-0657		.Base	D	1
020A	801-RJ7-0676		.Base	A, B	2
020C	801-RJ7-0684		.Base	C, D, E, F	2
020B	801-RJ7-0909		.Base	B	1
020D	801-RJ7-0917		.Base	D	1
020C	801-RJ7-0957		.Base	C, E, F	2
030A	801-RJ7-0112		.Base		4
030C	801-RJ7-0162		.Base	C	2
030	801-RJ7-0232		.Base	F	2

- item not illustrated

# MADELEC AERO

FSCM : F9503

## ILLUSTRATED PARTS CATALOG

Fig. Item	Part Number	Airline Stock N°	Nomenclature	Usage Code	Units /Assy
			1234567		
040A	111-RJ7-001		.Photoluminescent Tape	A	822.4 in.
040B	111-RJ7-001		.Photoluminescent Tape	B, D, E	828.4 in.
040C	111-RJ7-001		.Photoluminescent Tape	C	813.2 in.
040F	111-RJ7-001		.Photoluminescent Tape	F	825.2 in.
050A	211-RJ7-SA001		.Photoluminescent Tape	A	274.4 in.
050B	211-RJ7-SA001		.Photoluminescent Tape	B	356.4 in.
050C	211-RJ7-SA001		.Photoluminescent Tape	C, E, F	334.4 in.
050D	211-RJ7-SA001		.Photoluminescent Tape	D	300.4 in.
060A	211-RJ7-SA002		.Photoluminescent Tape		4
070A	505-802		.Cover	A	1144.8 in.
070B	505-802		.Cover	B	1184.5 in.
070C	505-802		.Cover	C	1197.6 in.
070D	505-802		.Cover	D	1170.8 in.
070E	505-802		.Cover	E	1204.8 in.
070F	505-802		.Cover	F	1201.6 in.
080A	505-8031		.End Cap		16
080A	505-8031		.End Cap	C, F	20

- item not illustrated

# MADELEC AERO

FSCM : F9503

## ABBREVIATED COMPONENT MAINTENANCE MANUAL

TASK 33-52-13-000-801

### 4. Removal and Disassembly

#### 1. Job set-up information :

- a) Consumable Materials : None
- b) Tool : None
- c) Referenced information : None

#### 2. Procedure :

- a) Lift up an end of the cover and remove it
- b) Remove the photoluminescent tape and the pieces of double side adhesive
- c) Remove the end-cap (if applicable)
- d) Lift up an end of the base and remove it
- e) Remove the double side adhesive on the floor and clean the working zone.

TASK 33-52-13-400-801

### 5. Installation and Assembly

#### 1. Job set-up information :

- d) Consumable Materials : Double side adhesive (not provided)
- e) Tool : None
- f) Referenced information : None

#### 2. Procedure :

- a) Clean the working zone
- b) Install double side adhesive on the floor
- c) Position the base on the double side adhesive
- d) Install an end-cap if applicable
- e) Position the photoluminescent tape on the base ( yellow side on top )
- f) Fix the photoluminescent tape with double side adhesive to each end
- g) Position the cover and snap it into place over the base
- h) Position the carpet.

# MADELEC AERO

FSCM : F9503

## ABBREVIATED COMPONENT MAINTENANCE MANUAL

### 6. Cleaning

#### A. General

To clean the photoluminescent tape, use a humid rag.

To clean the base P/N 801-RJ7-xxxx and the cover P/N 505-802 , use mild soap solution and a soft lint-free cloth.

NOTE : IT IS RECOMMENDED TO CLEAN THE COMPONENTS EVERY A-CHECK OR AT INTERVALS OF 30 DAYS MAXIMUM.

TASK 33-52-13-300-801

### 7. Repair:

SUBTASK 33-52-13-300-001

#### A. Repair

- (1) Remove and replace Photoluminescent tape P/N **111-RJ7-001**, **211-RJ7-SA001** and **211-RJ7-SA002** if the lifetime of 5 years is overtaken. (The end date is printed regularly at back of the photoluminescent tape)

SUBTASK 33-52-13-300-002

#### B. Repair

- (1) Remove and replace Cover P/N **505-802** if damaged or broken

**MADELEC AERO**  
FSCM : F9503

**ABBREVIATED COMPONENT MAINTENANCE MANUAL**

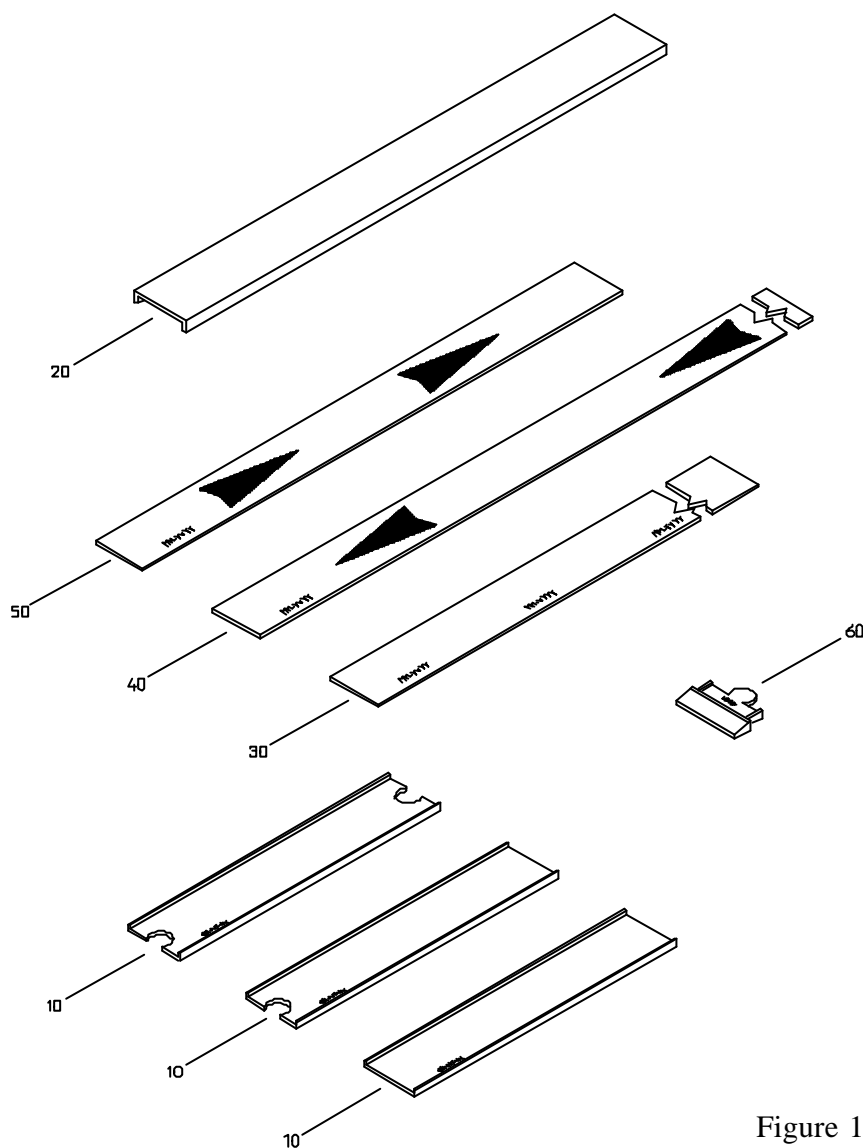

Figure 1

**Nomenclature**

Fig. Item	P/N	Airline Stock N°	Nomenclature	Use	Units/ Assy
10	801-RJ7-xxxx <sup>(1)</sup>		Base		Var
20	505-802		Translucent Cover		Var
30	111-RJ7-001		Photoluminescent tape		Var
40	211-RJ7-SA001		Photolum. tape with Arrows		Var
50	211-RJ7-SA002		Photolum. tape with Arrows		Var
60	505-8031		End Cap		Var

<sup>(1)</sup> -xxxx for the length, see IPC 33-52-13 for details