

# MADELEC AERO

FSCM : F9503

## ABBREVIATED COMPONENT MAINTENANCE MANUAL

### PHOTOLUMINESCENT FLOOR PROXIMITY EMERGENCY ESCAPE PATH MARKING SYSTEM TYPE 566 FOR DE HAVILLAND DASH 8-Q400

#### LIST OF REVISIONS

Rev. No.	1	2	3	4	5	6	7
Rev. Date	Jan 04/99	Sept 09/99					

#### LIST OF EFFECTIVE PAGES

Page 1 of 5    Sept 09/99                      Page 2 of 5    Sept 09/99                      Page 3 of 5    Sept 09/99  
Page 4 of 5    Sept 09/99                      Page 5 of 5    Sept 09/99

TASK 33-52-12-870-801

#### 1. Description and operation

The system consists of photoluminescent strips installed along each side of cabin passengers aisle. Each strip consists of a photoluminescent tape installed inside a polycarbonate profile consisted of a translucent cover and a base fitted together. End caps are installed to every strip end.

The system is installed on the floor with double side adhesive.

The system is consisted of two types of profile : type 505 and type 507. The type 507 pinches the carpet on the floor.

Approximate Dimensions :

- Type 505 : thickness = 0.2 inch; width = 1.38 inch
- Type 507 : thickness : 0.315 inch; width : 2.125 inch

#### 2. Testing and Fault Isolation

Not Applicable

#### 3. Schematics and Wiring Diagrams

Not Applicable

# MADELEC AERO

FSCM : F9503

## ABBREVIATED COMPONENT MAINTENANCE MANUAL

TASK 33-52-12-000-801

### 4. Removal and Disassembly

#### 1. Job set-up information :

- a) Consumable Materials : None
- b) Tool : None
- c) Referenced information : None

#### 2. Procedure :

- a) Lift up an end of the cover and remove it
- b) Remove the photoluminescent tape and the pieces of double side adhesive
- c) Remove the end-cap (if applicable)
- d) Lift up an end of the base and remove it
- e) Remove the double side adhesive on the floor and clean the working zone.

TASK 33-52-12-400-801

### 5. Installation and Assembly

#### 1. Job set-up information :

- d) Consumable Materials : Double side adhesive (not provided)
- e) Tool : None
- f) Referenced information : None

#### 2. Procedure :

- a) Clean the working zone
- b) Install double side adhesive on the floor
- c) Position the base on the double side adhesive
- d) Install an end-cap if applicable
- e) Position the photoluminescent tape on the base ( yellow side on top )
- f) Fix the photoluminescent tape with double side adhesive to each end
- g) Position the carpet (for type 507)
- h) Position the cover and snap it into place over the base
- i) Position the carpet (for type 505).

# MADELEC AERO

FSCM : F9503

## ABBREVIATED COMPONENT MAINTENANCE MANUAL

### 6. Cleaning

#### A. General

To clean the photoluminescent tape, use a humid rag.

To clean the cover P/N 802-DH8-xxx and 812-DH8-xxx, use a weak detergent agent.

TASK 33-52-12-300-801

### 7. Repair:

SUBTASK 33-52-12-300-001

#### A. Repair

- (1) Remove and replace Photoluminescent tape P/N **111-DH8-xxx** if the lifetime of 5 years is overtaken. (The end date is printed regularly at back of the photoluminescent tape)

SUBTASK 33-52-12-300-002

#### B. Repair

- (1) Remove and replace Cover P/N **802-DH8-xxx** and P/N **812-DH8-xxx** if damaged or broken

# MADELEC AERO

FSCM : F9503

## ABBREVIATED COMPONENT MAINTENANCE MANUAL

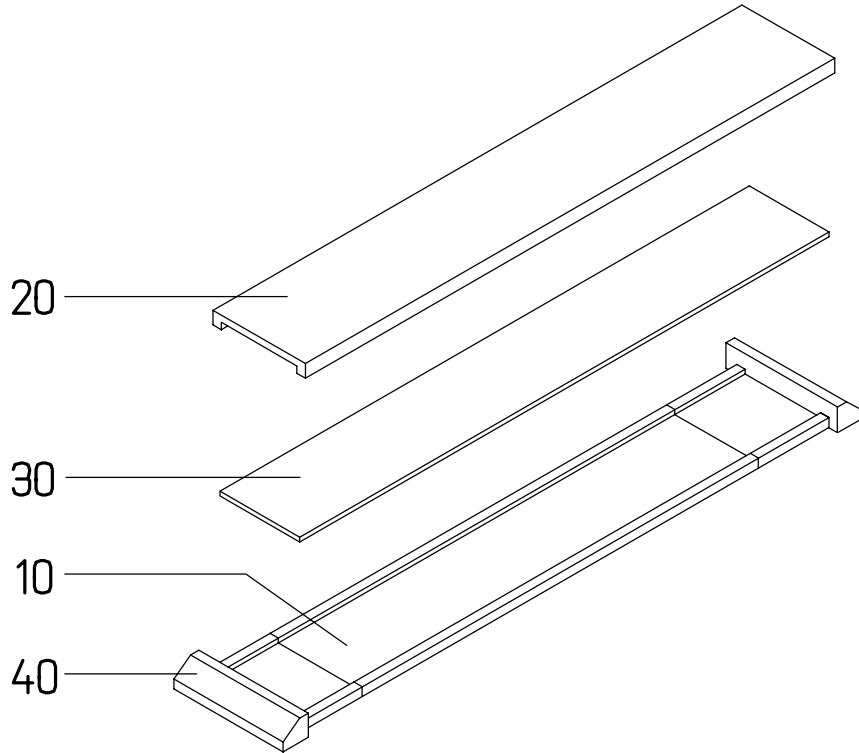

Figure 1

### Nomenclature

Fig. Item	P/N	Airline Stock N°	Nomenclature	Use	Units/ Assy
10	801-DH8-xxx		Base	1	/
20	802-DH8-xxx		Translucent Cover	1	/
30	111-DH8-xxx		Photoluminescent tape	1	/
40	505-8031		End Cap	2	/

# MADELEC AERO

FSCM : F9503

## ABBREVIATED COMPONENT MAINTENANCE MANUAL

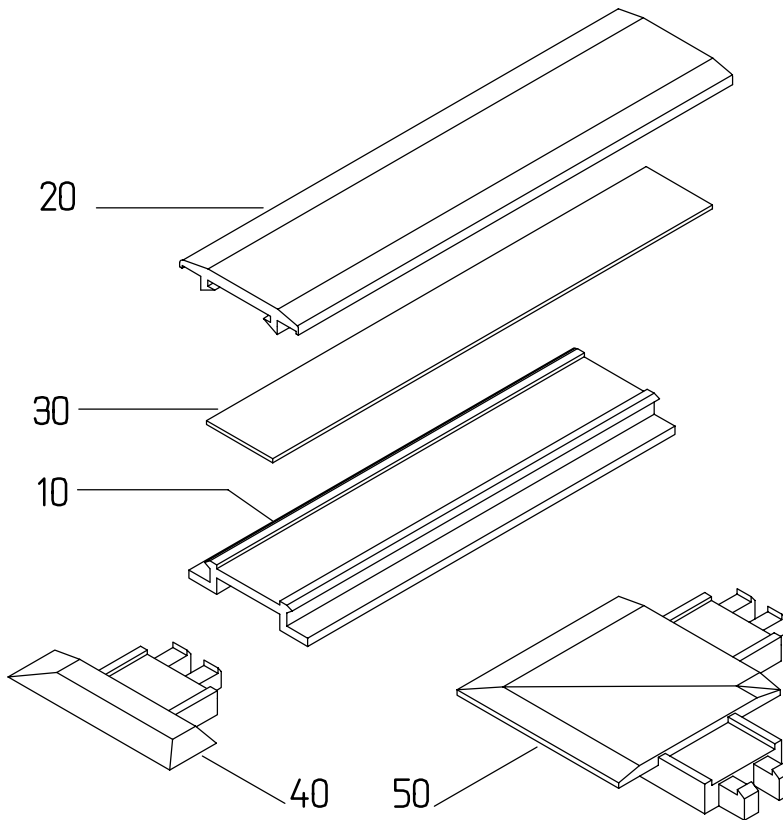

Figure 2

### Nomenclature

Fig. Item	P/N	Airline Stock N°	Nomenclature	Use	Units/ Assy
10	811-DH8-xxx		Base	1	/
20	812-DH8-xxx		Translucent Cover	1	/
30	111-DH8-xxx		Photoluminescent tape	1	/
40	507-813		End Cap	1	/
50	507-814		End Cap 90°	1	/