

**FLOOR PROXIMITY EMERGENCY ESCAPE PATH MARKING
PHOTOLUMINESCENT SYSTEM TYPE 566 FOR ATR 42 / 72**

Configuration : 566A4201 and 566A7201

- P/N : 566A72SA101
- 566A72SA102
- 566A72SA103
- 566A72SA105
- 566A72SA106
- 566A72SA107
- 566A72SA500
- 566A72SA501
- 566A72SA510
- 566A72SA520

ORIGINAL
en Rouge

LIST OF REVISIONS

Rev. No.	1	2	3	4	5	6	7
Rev. Date	Jan 15/99	Feb 15/05	Feb 23/09				

LIST OF EFFECTIVE PAGES

Page 1 of 4 Feb 23/09 Page 2 of 4 Feb 23/09
Page 3 of 4 Feb 23/09 Page 4 of 4 Feb 23/09

1. Description

The system consists of photoluminescent strips installed along each side of cabin passengers aisle. Each strip consists of a photoluminescent tape installed inside a polycarbonate profile consisted of a translucent cover and a base fitted together. End caps are installed to every strip end. The system is installed on the floor with double side adhesive.

2. Electrical drawing

N/A

3. Check & Adjust

N/A

4. Maintenance Review Board

- Retirement Lives for Safe Items :

P/N	Description	Retirement life
111ATRxxx	Photoluminescent tape	8 years *

* the end date is printed regularly on the photoluminescent tape.

- Unscheduled Maintenance Planning :

- Cover P/N **802ATRxxx** : Replace when damaged or broken
- Cleaning : When it's necessary, remove the cover and clean the photoluminescent tape (dust...). Clean the translucent cover with humid rag and polish it with a weak detergent agent.

5. Maintenance

• Remove/Install Photoluminescent Floor Proximity Emergency Lighting System :

1. Materials : Not Applicable
2. Special tools and Equipment : Not Applicable
3. Standard tools and equipment : Not Applicable
4. Consumable Materials : Not Applicable
5. Expendable Parts : Not Applicable
6. Referenced Procedures : Figure 1 (type 505)
7. Procedure of removal :
 - a) Lift up an end of the cover (20) and remove it
 - b) Remove the photoluminescent tape (30)
 - c) Remove the remaining double side adhesive (50) from the photoluminescent tape with a cleaning agent and/or use a nonmetallic scraper
 - d) Remove the two end-caps (40)
 - e) Lift up an end of the base (10) and remove it
 - f) Remove the double side adhesive on the floor and clean the working zone.
8. Procedure of installation :
 - a) Clean the working zone
 - b) Install double side adhesive on the floor
 - c) Position the base (10) on the double side adhesive
 - d) Install the two end-caps (40)
 - e) Put a small piece of double of double sided adhesive (50) at the back (white side) and at each end of the photoluminescent tape (30)
 - f) Position the photoluminescent tape on the base (yellow side on top)
 - g) Position the cover (20) and snap it into place over the base.

Figure 1

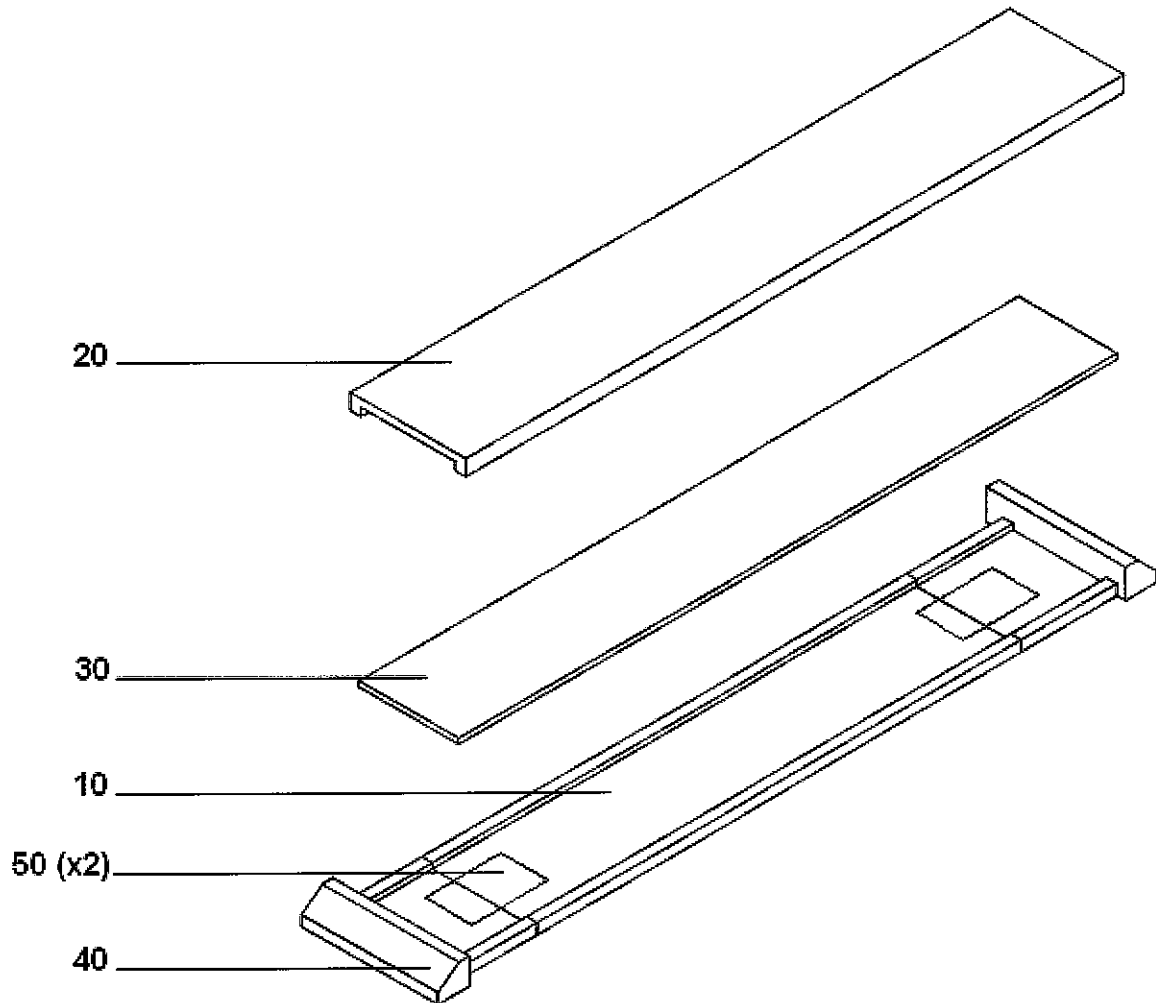

Nomenclature

Fig. Item	P/N	Airline Stock N°	Nomenclature	Use	Units/ Assy
10	801ATRxxx		Base	1	/
20	802ATRxxx		Translucent Cover	1	/
30	111ATRxxx		Photoluminescent tape	1	/
40	505-8031		End Cap	2	/
50	9088 FL		Adhesive double sided	2	/