

MADELEC AERO

10-62-01 / COMPONENT MAINTENANCE MANUAL

HIGHLIGHTS

REVISION N° 1 - Date de révision 4 May 1995

CHAPTER	PAGE	REMARKS
All	All	This issue takes the place of all others CMM of the Chartholder P/N 10-62-01 existing. It squares with the standardisation of our Technical Documentation according to the ATA100.

MADELEC AERO

CONTROL WHEEL CHARHOLDER

PART N°: 10-62 & 10-62-01

**COMPONENT MAINTENANCE MANUAL
WITH
ILLUSTRATED PARTS LIST**

33-10-90

MADELEC AERO
COMPONENT MAINTENANCE MANUAL
PART N°: 10-62 & 10-62-01

LIST OF EFFECTIVE PAGES

SUBJECT	Page	Date	SUBJECT	Page	Date
List of Effective Page	1	4.5.95			
Record of Revision	1	4.5.95			
Table of Contents	1	4.5.95			
General	1	4.5.95			
	2	4.5.95			
Figure	1001	4.5.95			
	1002	4.5.95			
Nomenclature	1003	4.5.95			
	1004	4.5.95			

MADELEC AERO
COMPONENT MAINTENANCE MANUAL
PART N°: 10-62 & 10-62-01

RECORD OF REVISIONS

REVISION	
N°	Date
1	May 4, 95

INSERTION	
Date	By

REVISION	
N°	Date

INSERTION	
Date	By

MADELEC AERO
COMPONENT MAINTENANCE MANUAL
PART N°: 10-62 & 62-10-01

TABLE OF CONTENTS

SUBJECT	Chapter Section Subject	Page	Effectivity
COMPONENT MAINTENANCE MANUAL			
Description & Operation	General	1	
Fault Isolation	General	2	
Adjustment/Test	General	2	
Removal / Installation	General	2	
ILLUSTRATED PARTS CATALOG			
Figure 1	Figure	1001	
Figure 2	Figure	1002	
Nomenclature	Nomenclature	1003	
	Nomenclature	1004	

MADELEC AERO

10 - 62 & 62-01 / Component Maintenance Manual

1. DESCRIPTION & OPERATION

A chartholder is attached to the center post of the captain's and first officer's control Wheel.

This chartholder is lighted and the light assembly is springloaded against the plate to retain approach chart. The angle of the chart can be adjusted with springs.

The light intensity can be adjusted by turning the knob.

To retain the chart, push at point A and insert chart at point B.

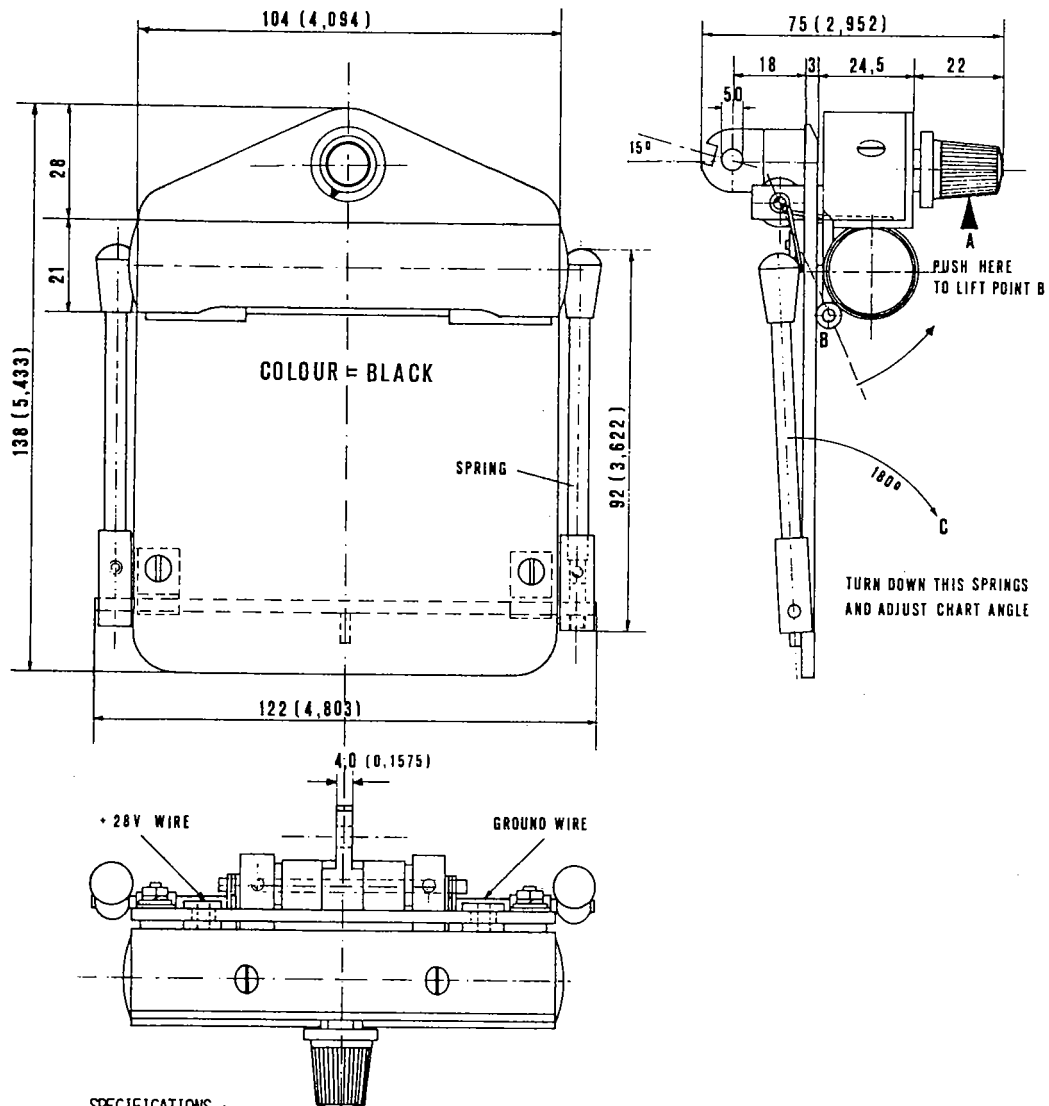

SPECIFICATIONS :

OVERALL SIZE	138 x 122 x 70 MM
POWER CONSUMPTION	0,34 AMPS / 28 VOLTS
VOLTAGE	24 - 30 VOLTS
WEIGHT	0,270 KG / 0,595 LBS

2. FAULT ISOLATION

Wiring Diagram

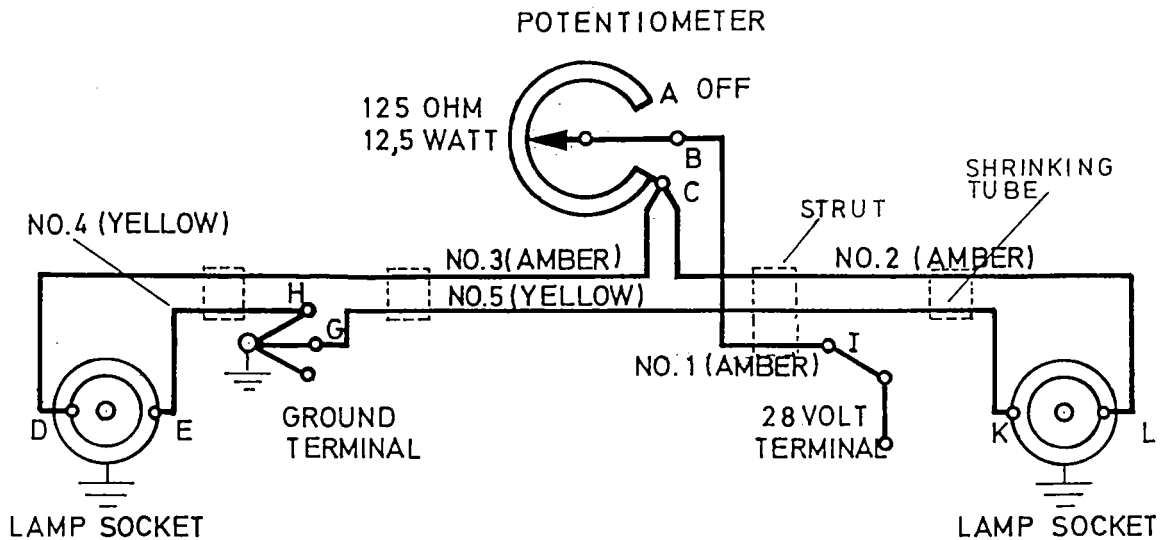

3. ADJUSTMENT / TEST

Aimlessly

4. REMOVAL / INSTALLATION

To disconnect the light assembly from the plate, proceed as follows:
(Figure - Page 2)

- A. Unscrew both screws Rep. 44
- B. Put down the spring Rep. 29
- C. Pull out the shaft Rep. 32

To reassemble both elements, proceed as follows:

- D. Pull back the shaft Rep. 32
- E. Put back the spring Rep. 29
- F. Screw both screws Rep. 44

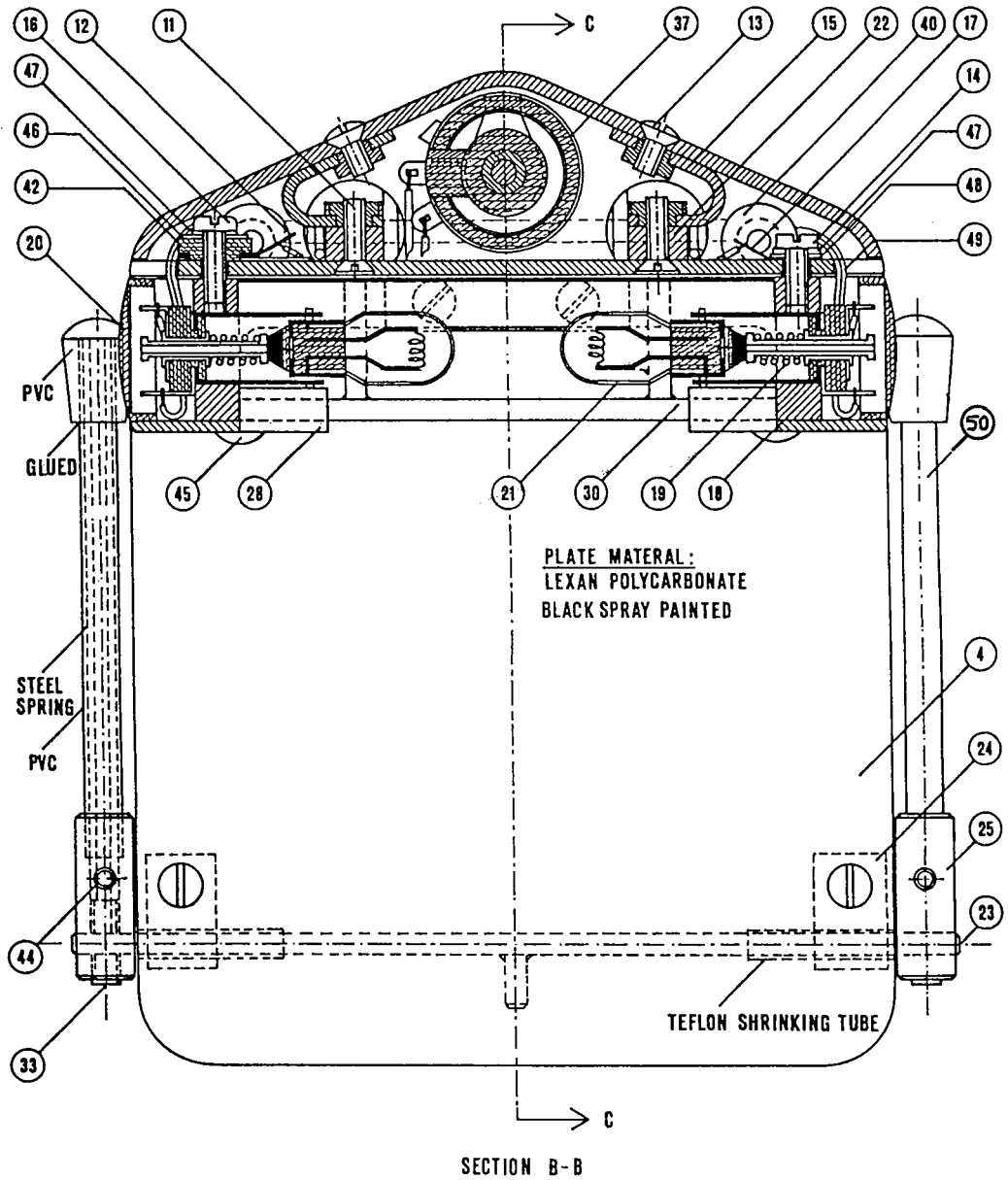

FIGURE N° 1

33-10-90

Figure 1

Page 1001

May 4 1995

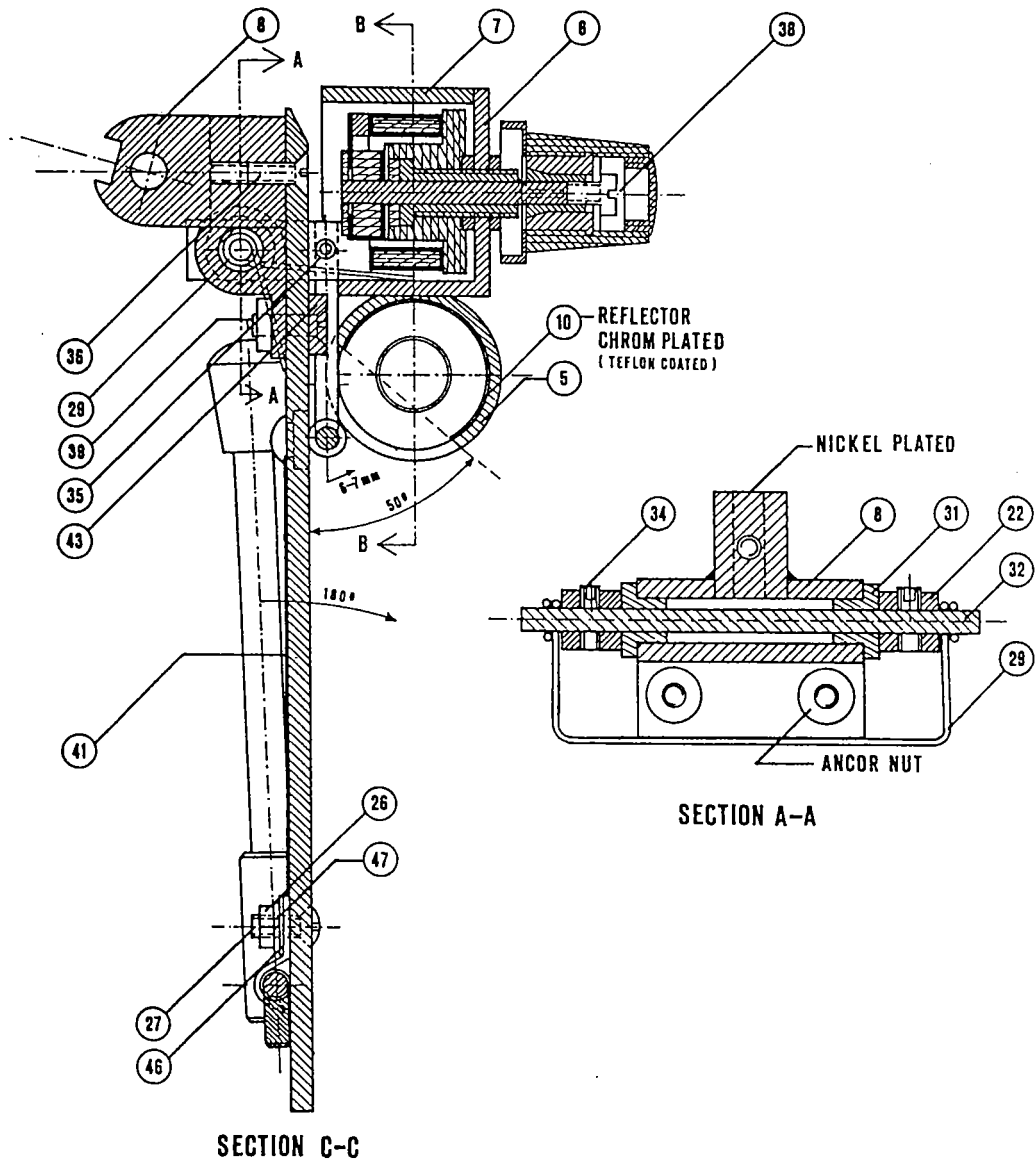

FIGURE N° 2

33-10-90

Figure 2
Page 1002
May 4 1995

MADELEC AERO

10-62 & 62-01 / ILLUSTRATED PARTS CATALOG

Fig. Item	Part Number	AIRLINE Stock N°	Nomenclature	Usage	Units/Assy
-001A	10-62		Control Wheel Chartholder		RF
-001B	10-62-01		Control Wheel Chartholder		RF
004A	10-62-4		.Plate		1
005A	10-62-5		.Reflector Tube		1
006A	10-62-6		.Bracket		1
007A	10-62-7		.Covering		1
008A	10-62-8		.Joint Piece		1
010A	10-62-10		.Reflector Tube Insert		1
011A	10-62-11		.Screw M3x10mm/90°		2
012A	10-62-12		.Soldering Terminal +		2
013A	10-62-13		.Screw M3x6mm/90° Black		2
014A	10-62-14		.Screw M3x8mm/Cyl.		1
015A	10-62-15		.Bracket		2
016A	10-62-16		.Screw M3x10mm/Pan Head		1
017A	10-62-17		.Soldering Terminal -		1
018A	08-62-18		.Ring		2
019A	08-62-19		.Lamp Socket		2
020A	10-62-20		.Cover		2
021A	08-62-21		.Lamp GE 333 (28 V / 0.17 A)	1A	2
021B	10-62-21		.Lamp GE 1864 (28 V / 0.17 A)	1B	2
022A	10-62-22		.Strut		2
023A	08-62-23		.Shaft		1
024A	10-62-24		.Leaf Spring		2
025A	08-62-25		.Sleeve		2
026A	08-62-26		.Hexagonal Nut M3		2
027A	10-62-27		.Screw M3x8/90° Black		2
028A	10-62-28		.Silicon Tube		2
029A	08-62-29		.Spring		1
030A	10-62-30		.Retaining Bracket		1
031A	08-62-31		.Bushing		2
032A	08-62-32		.Shaft		1
033A	08-62-33		.Hexagonal Screw M4x4mm		2
034A	08-62-34		.Hexagonal Screw M3x3mm		2
035A	08-62-35		.Hexagonal Screw M3x4mm		2
036A	08-62-36		.Screw M3x8mm/90°		1
037A	08-62-37		.Potentiometer 125 Ohms		1

- item not illustrated

33-10-90

Nomenclature

Page 1003

May 4 1995

MADELEC AERO
10-62 & 62-01 / ILLUSTRATED PARTS CATALOG

Fig. Item	Part Number	AIRLINE Stock N°	Nomenclature	Usage	Units/Assy
038A	08-62-38		.Knob Cover	1A	1
038B	10-62-38		.Knob Cover	1B	1
039A	10-62-39		.Screw M3x10mm/90°		2
040A	10-62-40		.Rubber Grommet		2
041A	10-62-41A		.Decal		1
041B	10-62-41B		.Decal	1A	1
042A	10-62-42		.Isolation Post	1B	1
043A	10-62-43		.Retainer Bracket		1
044A	08-62-44		.Hexagonal Screw M3x3mm		2
045A	10-62-45		.Rubber Grommet		2
046A	10-62-46		.Washer 9x3mm		3
047A	10-62-47		.Spring Washer 3mm		4
048A	10-62-48		.Washer 7x3mm		1
049A	10-62-49		.Set of Wire		1
050A	10-62-25AB		.Coil Spring		2

33-10-90

Nomenclature

Page 1004

May 4 1995

MADELEC AERO
10-62A100 / ILLUSTRATED PARTS CATALOG

Fig. Item	Part Number	AIRLINE Stock N°	Nomenclature	Usage	Units/Assy
038A	08-62-381		.Knob Cover		1
039A	10-62-39		.Screw M3x10mm/90°		2
040A	10-62-40		.Rubber Grommet		2
041A	10-62-41D		.Decal		1
042A	10-62-42		.Isolation Post		1
043A	10-62-43		.Retainer Bracket		1
044A	08-62-44		.Hexagonal Screw M3x3mm		2
045A	10-62-45		.Rubber Grommet		2
046A	10-62-46		.Washer 9x3mm		3
047A	10-62-47		.Spring Washer 3mm		4
048A	10-62-48		.Washer 7x3mm		1
049A	10-62-49		.Set of Wire		1
050A	10-62-25AB		.Coil Spring		2

33-12-13

Nomenclature

Page 1004

June 29 1995